

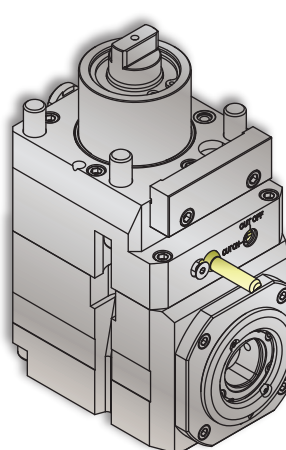

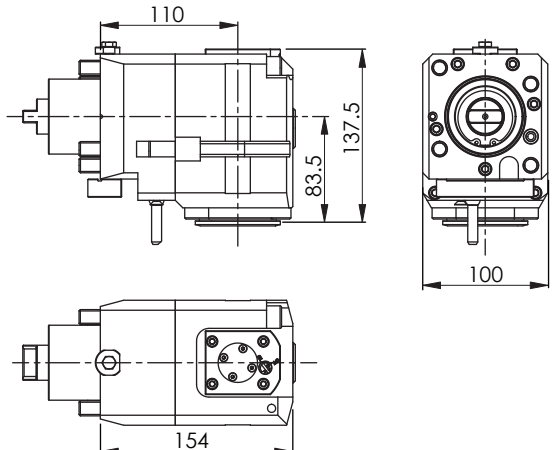



OKUMA

Radial Drilling and Milling Unit / Radial-Bohr-Fräseinheit
 Motorizzato Radiale di Foratura e Fresatura / Unité de Perçage et de Fraisage Radiale
 ラジアルドリルおよびミーリングユニット

Lathe Angular Unit • LAU 60-1 R C4									
Machine Types		2SP-2500H M							
  									
#				i	$n_2 \max$	$T_2 \max$	# 		
14800005170	Capto C4	 100 bar		1:1	6'000 min ⁻¹	60 Nm	14430100980		

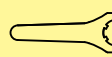
Notes / Notizen / Note / Notes / ㄨ ㄜ

--

Please check the machine strokes and the neighbor stations on potential overlaps - Bitte die Verfahrswege und die Nachbarstationen auf mögliche Überschneidungen überprüfen
 Si prega di verificare i percorsi e le stazioni adiacenti di potenziali sovrapposizioni - Vérifier les courses et qu'il n'y a pas de collisions possibles avec les stations voisines
 常に機械のストロークと、隣接するステーションにオーバーラップが無いが確認してください。
 Design data and dimensions subject to change - Konstruktions- und Massänderungen vorbehalten
 Cambiamento della costruzione e delle misure riservato - Droit de modification de structure et de cotes réservées
 設計仕様および寸法は通知することなく変更されます

