

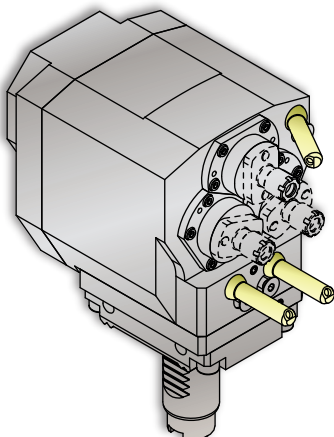

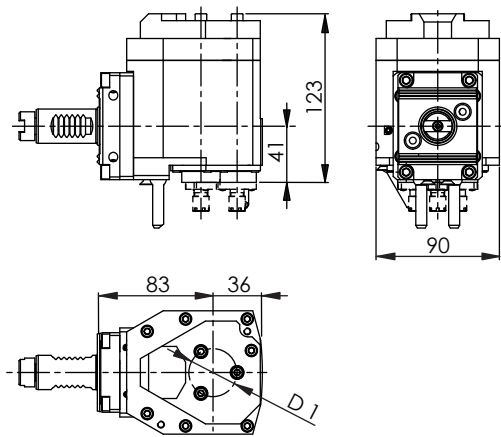

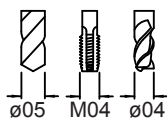





INDEX

Axial Drilling and Milling Unit / Axial-Bohr-Fräseinheit
 Motorizzato Assiale di Foratura e Fresatura / Unité de Perçage et de Fraisage Axiale
 アキシアルドリルおよびミーリングユニット

Lathe Unit Angular Unit Offset (High Speed) • LAUO 3-3 A										
Machine Types	C100 VDI 25	C200 VDI 25	G200 VDI 25							
  										
#				i $n_1 : n_2$	n_2 max	T_2 max	D1	#		
14801001460	SH10	 100 bar		1 : 3	18'000 min ⁻¹ *	3 Nm	35.20	-	-	
14801001470	SH10	 100 bar		1 : 3	18'000 min ⁻¹ *	3 Nm	35.55	-	-	
14801001410	SH10	 100 bar		1 : 3	18'000 min ⁻¹ *	3 Nm	38.95	-	-	

- * Only while 20% of the complete cycle time (risk of overheating)
- * Nur während 20% der gesamten Zykluszeit (Überhitzungsgefahr)
- * Utilizzare solo per il 20% del ciclo totale (rischio di surriscaldamento)
- * Utilisation limitée à 20% du temps de cycle total de la pièce (risque de montée en température trop importante)
- * 全サイクル時間の20%の場合(オーバーヒートのリスク)

Notes / Notizen / Note / Notes / メモ

Please check the machine strokes and the neighbor stations on potential overlaps - Bitte die Verfahrswege und die Nachbarstationen auf mögliche Überschneidungen überprüfen
 Si prega di verificare i percorsi e le stazioni adiacenti di potenziali sovrapposizioni - Vérifier les courses et qu'il n'y a pas de collisions possibles avec les stations voisines
 常に機械のストロークと、隣接するステーションにオーバーラップが無いが確認してください。
 Design data and dimensions subject to change - Konstruktions- und Massänderungen vorbehalten
 Cambiamento della costruzione e delle misure riservato - Droit de modification de structure et de cotes réservées
 設計仕様および寸法は通知することなく変更されます

