

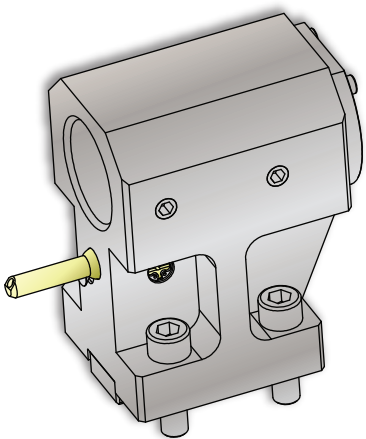

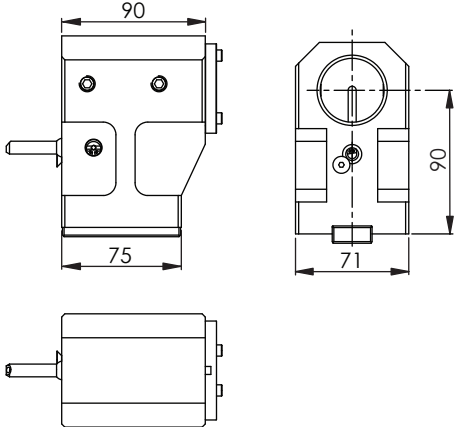

## OKUMA

Boring Bar Tool Holder / Bohrstangenaufnahme  
 Porta Barena e Punta / Porte Foret  
 ボーリングバーユニット

Lathe Angular Static • LAS 40-1 A				
<b>Machine Types</b>	2SP-150 H / HM / HG / HMG			
 				
#				# 
14910002410	ø 40	 100 bar		-

### Notes / Notizen / Note / Notes / ㄨㄛ

Please check the machine strokes and the neighbor stations on potential overlaps - Bitte die Verfahrswege und die Nachbarstationen auf mögliche Überschneidungen überprüfen  
 Si prega di verificare i percorsi e le stazioni adiacenti di potenziali sovrapposizioni - Vérifier les courses et qu'il n'y a pas de collisions possibles avec les stations voisines  
 常に機械のストロークと、隣接するステーションにオーバーラップが無いが確認してください。  
 Design data and dimensions subject to change - Konstruktions- und Massänderungen vorbehalten  
 Cambiamento della costruzione e delle misure riservato - Droit de modification de structure et de cotes réservées  
 設計仕様および寸法は通知することなく変更されます

