

ZAUM 25-1 A

for **Miyano**

6'000 min⁻¹ / rpm
i = 1:1

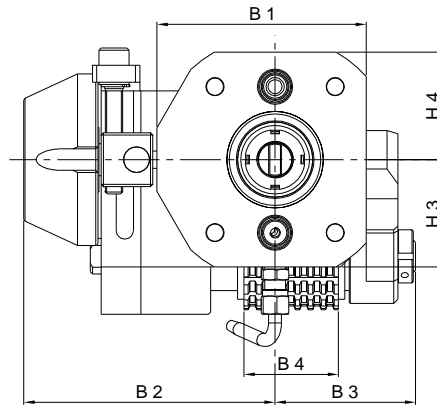
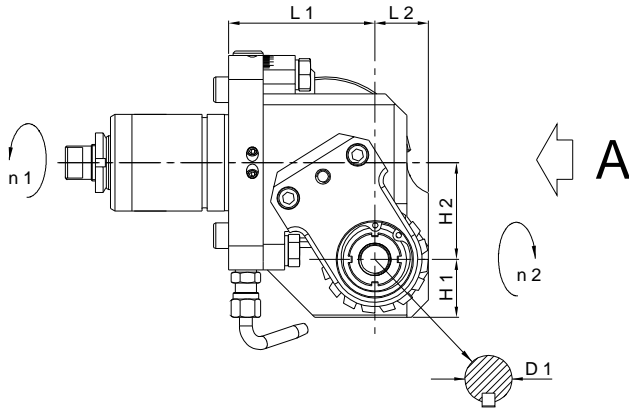
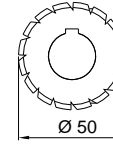

Axial- Fräseinrichtung Axial Milling Unit Unità assiale di fresatura Unité de fraisage axial	
Externe Kühlung P max. = 70 bar	EKZ
External coolant supply Coolant pressure max. = 70 bar	ECS
Liquido refrigerante esterno Pressione max. = 70 bar	LRE
Arrosage par l'extérieur Pression max. = 70 bars	APE

Benötigt **zwei** Werkzeugplätze!
Requires **two** tool places!
Richiede **due** posti utensile!
Encombrement sur **deux** postes de
toureille!

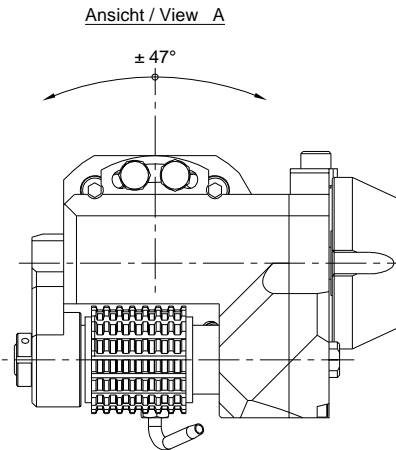
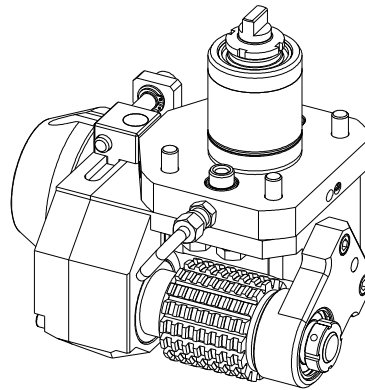
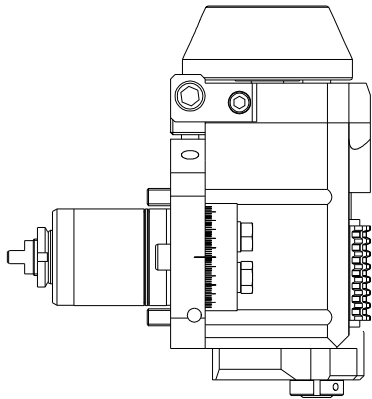

Machine Types	
ABX 51 TH2	BND 51 SY2
ABX 64 TH2	BNE 51 MSY
ABX 51 TH3	BNJ 42 SY
ABX 64 TH3	BNJ 51 SY

Bestell-Nr. Ref. No.	Axialkopf Axial Head	L 1	L 2	H 1	H 2	H 3	H 4	B 1	B 2	B 3	B 4 max.	D 1	Nm max.	Schmierung Lubrication	rpm max. min -1	i n 1 : n 2	Zubehör Accessory	Page	
A	14800002650	ZAUM 25-1 A	68	25	27	45	50	50	97.5	117	65.4	44	22	25	Fettschmierung Lubricant grease	6'000	1 : 1	Spannschlüssel / Spanners	019