

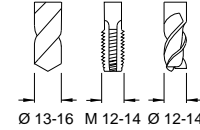

Turret 62 mm

6'000 min -1 / rpm
i = 1:1



Radial-Bohr-Fräseinrichtung
Radial Drilling and Milling Unit
Unità radiale di foratura e fresatura
Unité de perçage et de fraisage radial

Externe Kühlung EKZ
Interne Kühlmittelzuführung IKZ
P max. = 70 bar
kein Trockenlauf!

External coolant supply ECS
Coolant through the spindle CTS
Coolant pressure max. = 70 bar
Don't run without coolant!

Liquido refrigerante esterno LRE
Liquido refrigerante sul fuso LRF
Pressione max. = 70 bar
Non lavorare a secco!

Arrosage par l'extérieur APE
Arrosage par le centre APC
Pression max. = 70 bars
Ne pas tourner sans arrosage!

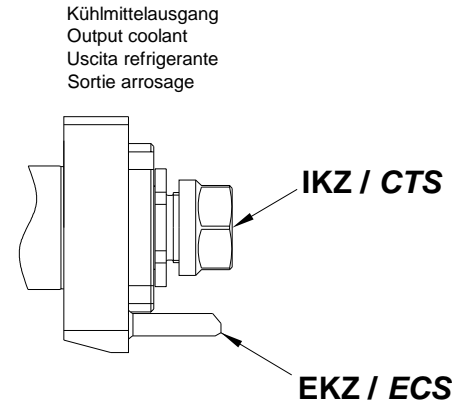
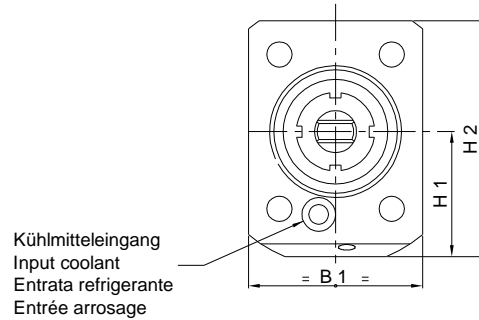
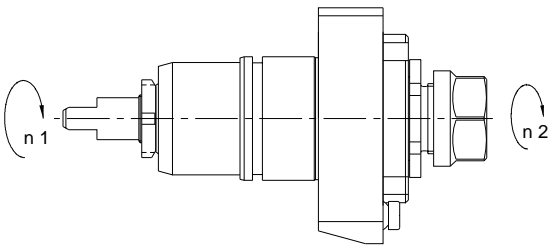

Spindelvarianten / Spindle executions / Esecuzione fusi / Exécutions de broches

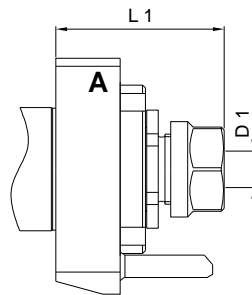
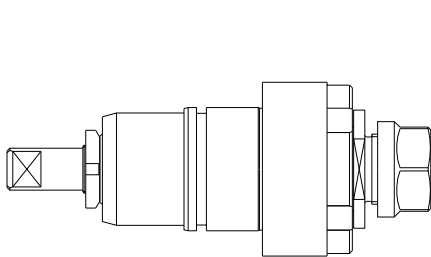

Hi-Q / ER 20 - ERC 20

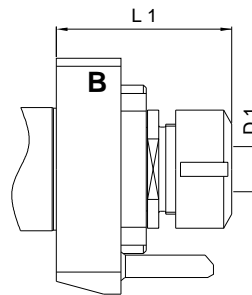

Hi-Q / ER 25 - ERC 25

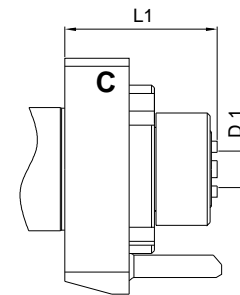

Hi-Q / ERAX 20 - ERAXC 20

	Bestell-Nr. IKZ Ref. No. CTS	Bestell-Nr. EKZ Ref. No. ECS	Radialkopf Radial Head	L 1	H 1	H 2	B 1	D 1 Ø max.	Nm max.	Schmierung Lubrication	rpm max. min -1	i n 1 : n 2	Zubehör Accessory
A	14101000550	14101000560	LLU 25-1 R Hi-Q / ER 20 LLU 25-1 R Hi-Q / ERC 20	60 65	44.5	84	62	13	25	Fettschmierung Lubricant grease	6'000	1:1	Spannzangen Coletts
B	14101000670	-	LLU 25-1 R Hi-Q / ER 25 LLU 25-1 R Hi-Q / ERC 25	62.5 67.5	44.5	84	62	16	25	Fettschmierung Lubricant grease	6'000	1:1	Spannschlüssel Spanners
C	-	-	LLU 25-1 R Hi-Q / ERAX 20 LLU 25-1 R Hi-Q / ERAX C 20	54.3 59.3	44.5	84	62	13	25	Fettschmierung Lubricant grease	6'000	1:1	