

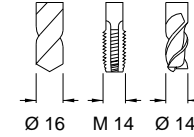

Turret 62 mm

6'000 min⁻¹ / rpm
i = 1:1



Axial-Bohr-Fräseinrichtung Drilling and Milling Axial Unit Testa assiale di foratura e fresatura Unité de perçage et de fraisage axial	
Externe Kühlung	EKZ
External coolant supply	ECS
Liquido refrigerante esterno	LRE
Arrosage par l'extérieur	APE

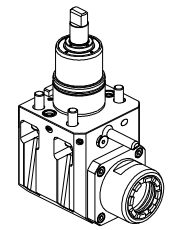
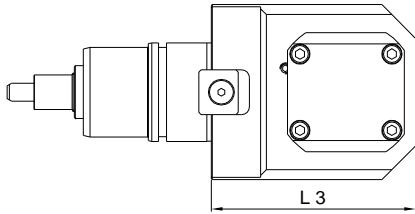
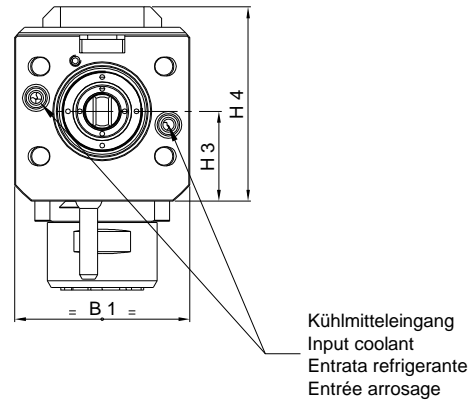
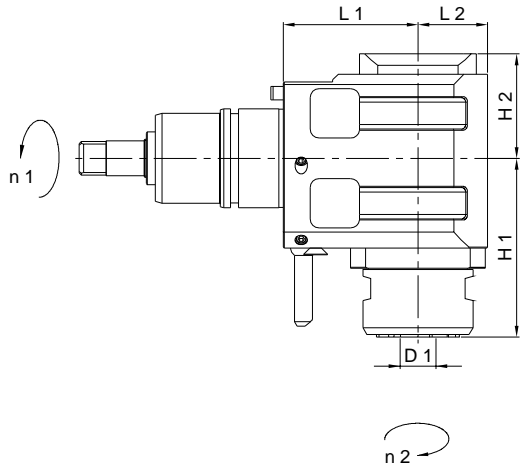

	Bestell-Nr. EKZ Ref. No. ECS	Axialkopf Axial Head	L 1	L 2	L 3	H 1	H 2	H 3	H 4	B 1	D 1 Ø	Nm max.	Schmierung Lubrication	rpm max. min ⁻¹	i n 1 : n 2	Zubehör Accessory
A	14800003690	LAU 25-1 A Hi-Q / ERAX 32	60	31	91	79.6	46.5	40	86.5	78	16	25	Fettschmierung Lubricant grease	6'000	1:1	Spannzangen / Coletts Spannschlüssel / Spanners