

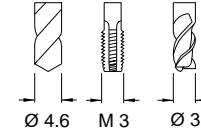

Turret 62 mm

12'000 min⁻¹ / rpm
i = 1:2



Radial-Bohr-Fräseinrichtung	
Radial Drilling and Milling Unit	
Unità radiale di foratura e fresatura	
Unité de perçage et de fraisage radial	
Externe Kühlung	EKZ
External coolant supply	ECS
Liquido refrigerante esterno	LRE
Arrosage par l'extérieur	APE

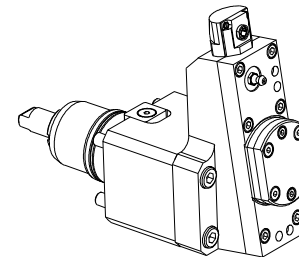
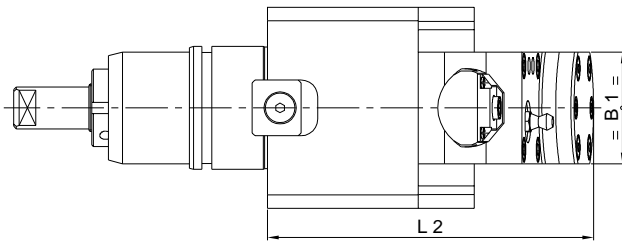
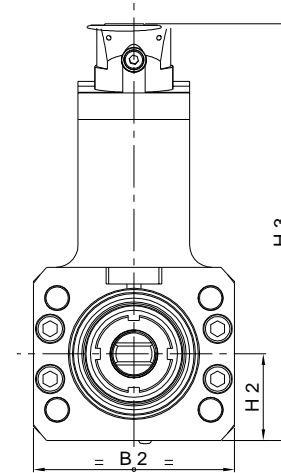
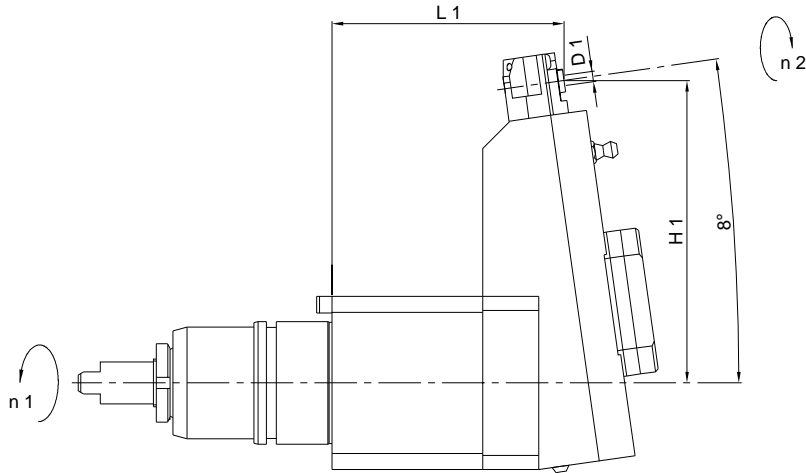

	Bestell-Nr. Ref. No.	Radialkopf 8° Radial Head	L 1	L 2	H 1	H 2	H 3	B 1	B 2	D 1 Ø	Nm max.	Schmierung Lubrication	rpm max. min ⁻¹	i n 1 : n 2	Zubehör Accessory
A	14802000540	LIDHS 4- 1 R	108.3	116.8	83.07	31	149.2 5	40	100	4.6	0.6	Fettschmierung Lubricant grease	12'000	1:2	-