

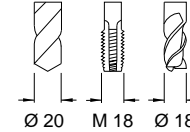

**6'000 min -1 / rpm**  
**i = 1:1**



Axial-Bohr-Fräseinrichtung Axial Drilling and Milling Unit Unità assiale di foratura e fresatura Unité de perçage et de fraisage axiale	
Externe Kühlung	EKZ
External coolant supply	ECS
Liquido refrigerante esterno	LRE
Arrosage par l'extérieur	APE

**Turret 100 mm**

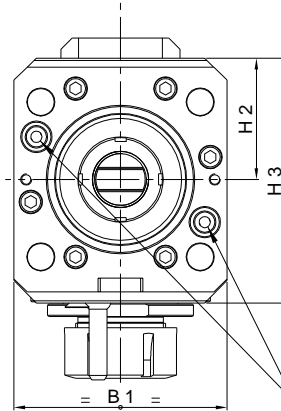
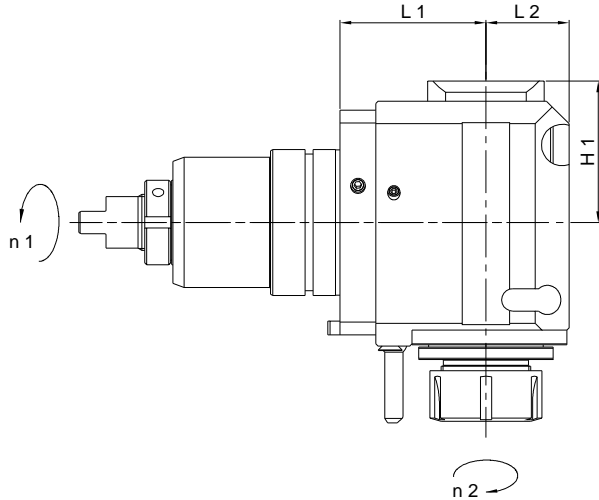

Kühlmitteleingang  
Input coolant  
Entrata refrigerante  
Entrée arrosage

**Spindelvarianten / Spindle executions / Esecuzione fusi / Exécutions de broches**

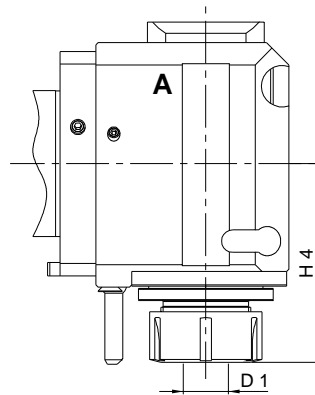
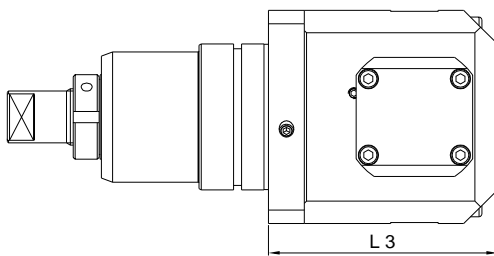

Hi-Q / ER 32

Best.-Nr. EKZ Ref. No. ECS	Axialkopf Axial Head	L 1	L 2	L 3	H 1	H 2	H 3	H 4	B 1	D 1 max. Ø	Nm max.	Schmierung Lubrication	rpm max. min -1	i n 1 : n 2	Zubehör Accessory
A 14800002690	LAU 60-1 A Hi-Q / ER 32	65	37	102	63	54	109	88.5	95	20	60	Fettschmierung Lubricant grease	6'000	1:1	Spannzangen / Coletts Spannschlüssel / Spanners