

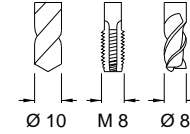

**12'000 min -1 / rpm**  
**i = 1:2**

**Turret 100 mm**



Axial-Bohr-Fräseinrichtung Axial Drilling and Milling Unit Unità assiale di foratura e fresatura Unité de perçage et de fraisage axiale	
Externe Kühlung	EKZ
External coolant supply	ECS
Liquido refrigerante esterno	LRE
Arrosage par l'extérieur	APE

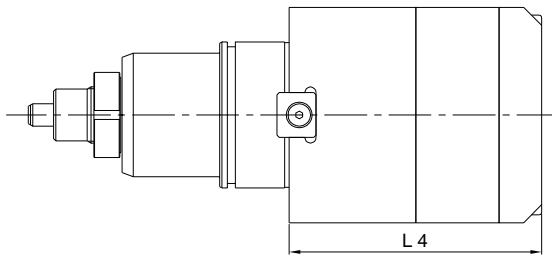
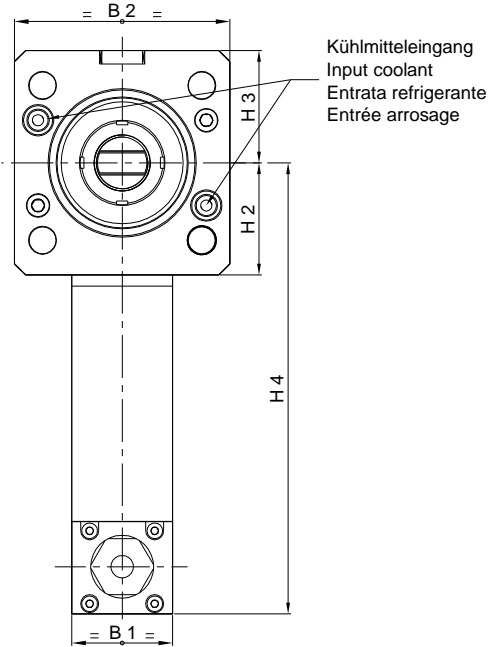
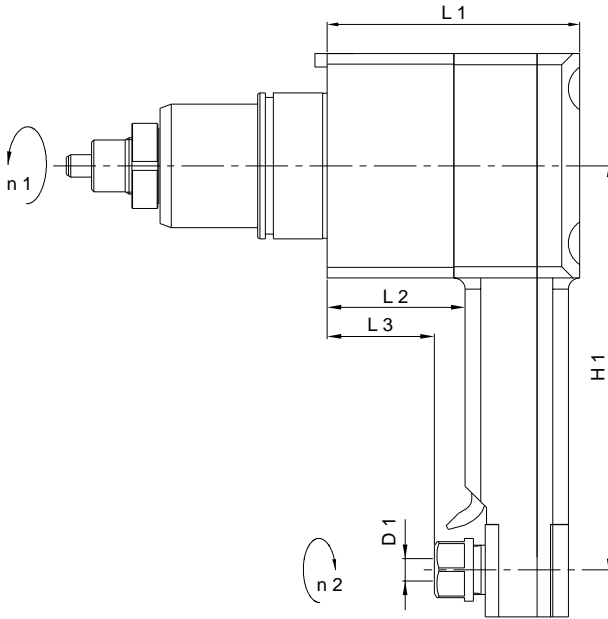

Bestell-Nr. Ref. No.	Winkelkopf Angle Head	L 1	L 2	L 3	L 4	H 1	H 2	H 3	H 4	B 1	B 2	D 1 Ø max.	Nm max.	Schmierung Lubrication	rpm max. min -1	i n 1 : n 2	Zubehör Accessory
A 14650000330	IDHSC 12-1 R Hi-Q / ER16	112.5	61.5	47.7	118.5	180	50	50	201	45	96	10	12	Fettschmierung Lubricant grease	12'000	1:2	Spannzangen / Coletts Spannschlüssel / Spanners