

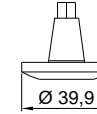

Turret 100 mm

5'000 min⁻¹ / rpm
i = 1:0,8214



Axial Fräseinrichtung Axial Milling Unit Unità assiale di foratura e fresatura Unité de fraisage axiale	
Externe Kühlung	EKZ
External coolant supply	ECS
Liquido refrigerante esterno	LRE
Arrosage par l'extérieur	APE

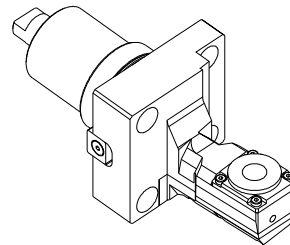
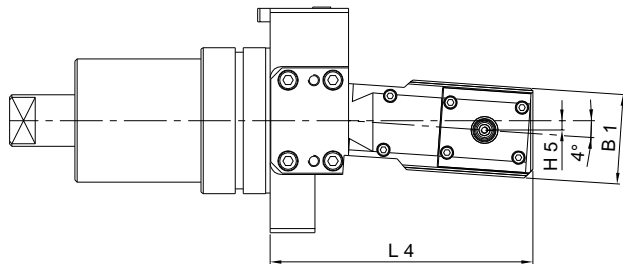
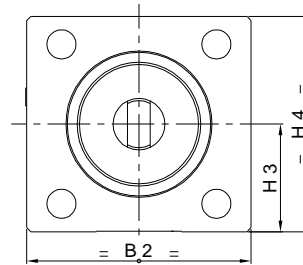
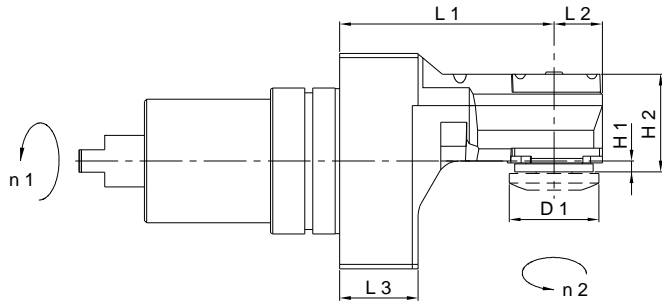

Bestell-Nr. Ref. No.	Axialkopf Axial Head	L 1	L 2	L 3	L 4	H 1	H 2	H 3	H 4	H 5	B 1	B 2	D 1 Ø	Nm max.	Schmierung Lubrication	rpm max. min ⁻¹	i n 1 : n 2	Zubehör Accessory	
A	14650000410	LIDH 4-1 A	95.5	21.5	35	117	4.8	43.5	48	96	4.231	40	100	39.9	4	Fettschmierung Lubricant grease	5'000	1:0.8214	-