

**Star** LLU 10-1 A

5'750 min -1 / rpm  
i= 1:1

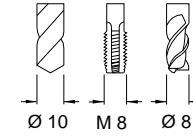

Radial-Bohr-Fräseinrichtung  
Radial Drilling and Milling Unit  
Unità radiale di foratura e fresatura  
Unité de perçage et de fraisage radial

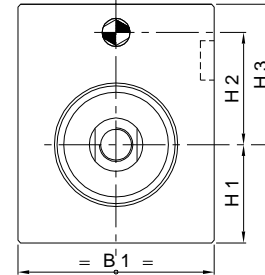
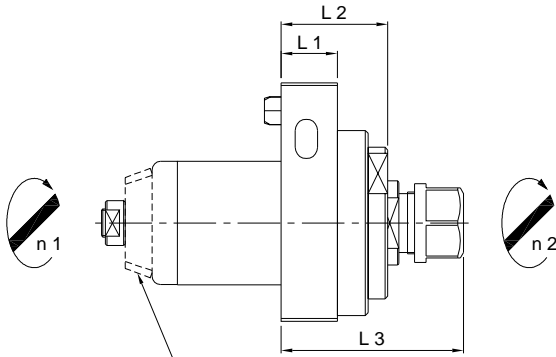

**Ref. No.: 1016500660**

Kegelrad ist im Lieferumfang nicht enthalten!

Bevel gear isn't included in the delivery!

Ingranaggio conico non fa parte della fornitura!

Engrenage conique n'est pas comprise dans la livraison!

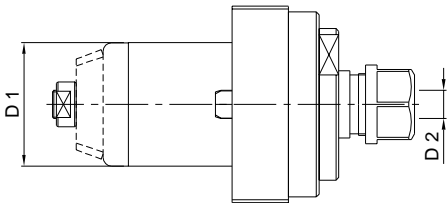

**Machine Types**  
ECAS-20T

**Auch einsetzbar auf / Also usable on**  
SV-12  
SV-20  
SV-32JII

	Ref. No. Star	Ref. No. SU-matic	Radialkopf Radial Head	L 1	L 2	L 3	B 1	H 1	H 2	H 3	D 1	D 2 max. Ø	Nm max.	Schmierung Lubrication	rpm max. min -1	i n 1 : n 2	Zubehör Accessory	Page
A	221-50	14101002320	LLU 13-1 A Hi-Q / ERM 16	20	38	65	70	35	40	50	44	10	13	Fettschmierung Lubricant grease	5'750	1:1	Spannzangen / Collets Dichtscheiben / Sealing Disks	014 014