

Star LAUOT 7-3+3 A

5'000 min⁻¹ / rpm
i = 1:1

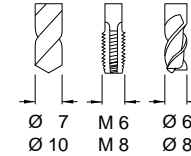

Axial-Bohr-Fräseinrichtung
Axial Drilling and Milling Unit
Unità assiale di foratura e fresatura
Unité de perçage et de fraisage axial

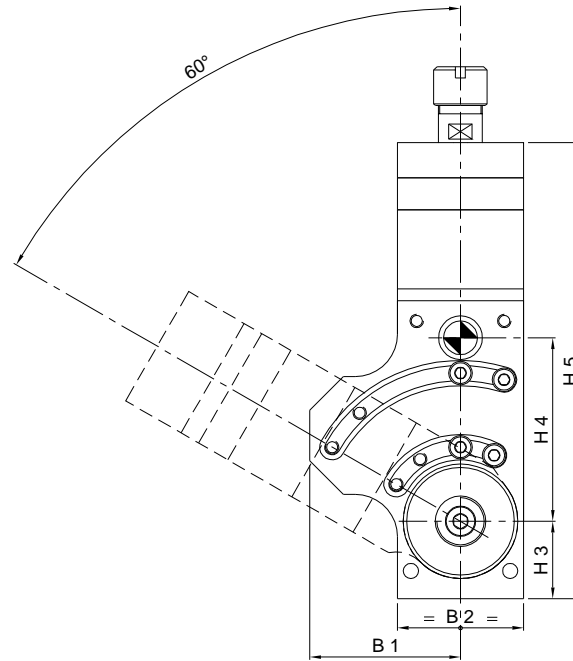
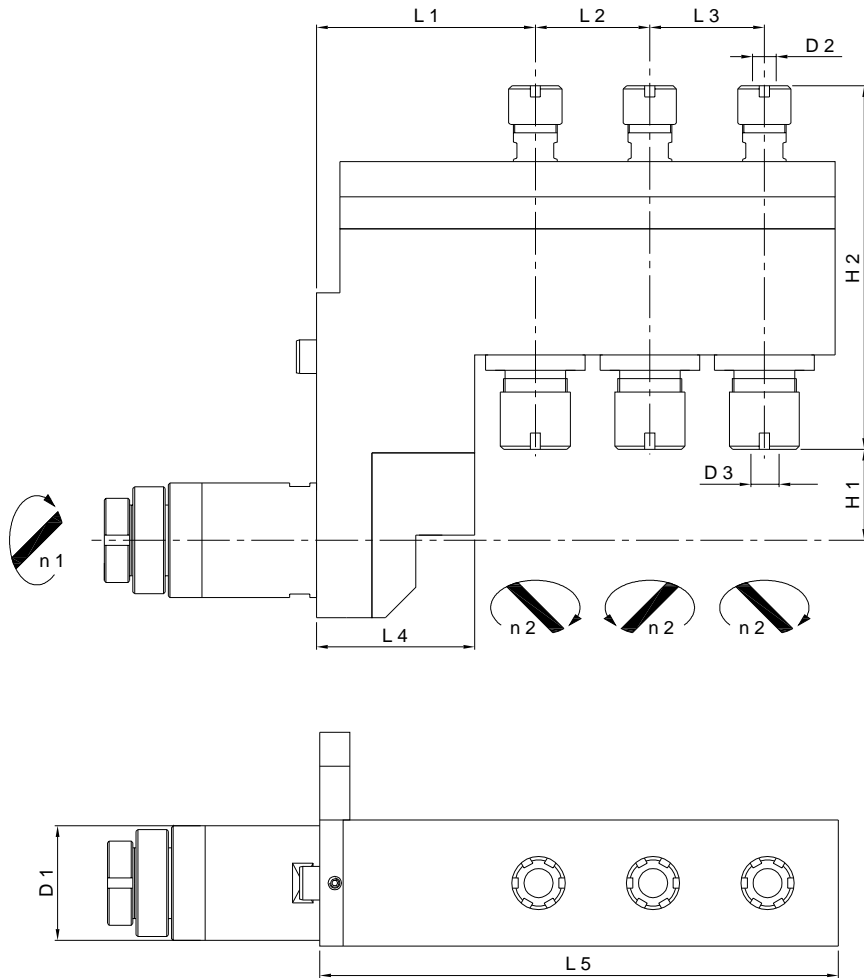

Machine Types
SV-38R

Auch einsetzbar auf / Also usable on
-

	Ref. No. Star	Ref. No. Su-matic	Axialkopf Axial Head	L 1	L 2	L 3	L 4	L 5	H 1	H 2	H 3	H 4	H 5	B 1	B 2	D 1	D 2 Ø max.	D 3 Ø max.	Nm max.	Schmierung Lubrication	rpm max. min ⁻¹	i n 1 : n 2	Zubehör Accessory	Page
A	671-59/S	14801000900	LAUOT 7-3+3 A 0-60° Hi-Q / ERM 11 + ERM 16	65	34	34	47	154	27	108	23	54.5	135.5	44.75	37.5	34	7	10	7	Fettschmierung Lubricant grease	5'000	1 : 1	Spannzangen / Collets Dichtscheiben / Sealing Disks	014 014