

OKUMA

Radial Drilling and Milling Unit / Radial-Bohr-Fräseinheit
 Motorizzato Radiale di Foratura e Fresatura / Unité de Perçage et de Fraisage Radiale
 ラジアルドリルおよびミーリングユニット

Lathe Linear Unit • LLU 60-1 R SU-matic®

Machine Types	Genos L300 (BMT) M / MW / MY / MYW	Genos L3000 (BMT) M / MW / MY	LB2000 EX M / MW / MY	LB3000 EX M / MW / MY / MYW	LU3000 EX M / MW / MY	Multus U3000 / U4000 / U5000 2S / 2S-W
---------------	---------------------------------------	----------------------------------	--------------------------	--------------------------------	--------------------------	---

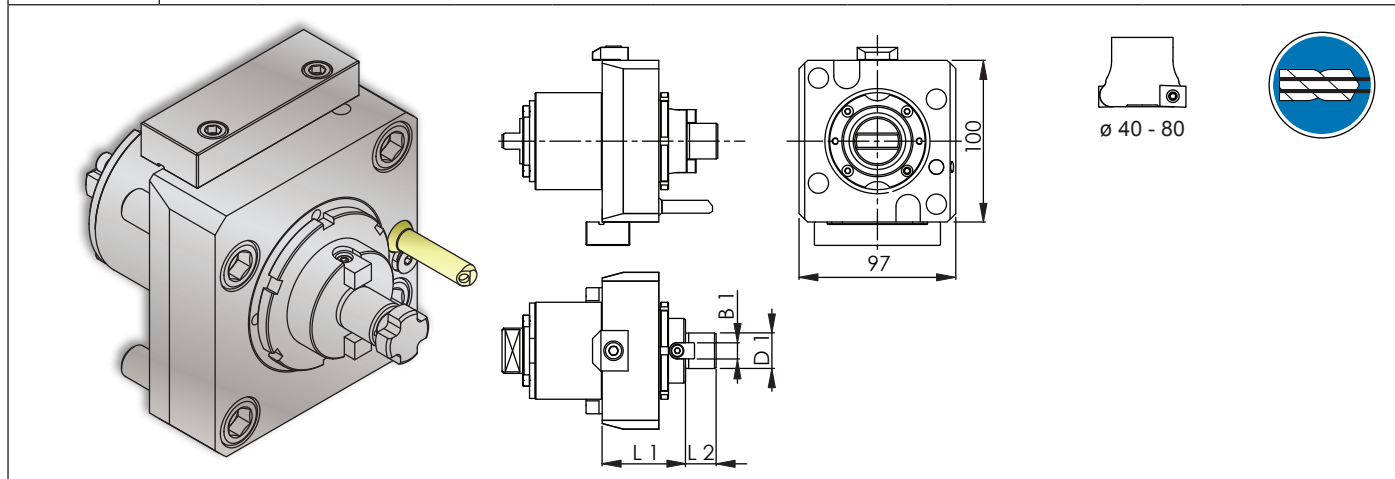

#			$n_1 : n_2$	i	$n_2 \text{ max}$	$T_2 \text{ max}$	L1	L2	B1	D1	#	
14101001310	ø16		100 bar		1 : 1	6'000 min ⁻¹	60 Nm	52.5	17	8	ø16	14430100210
14101001320	ø16		70 bar		1 : 1	6'000 min ⁻¹	60 Nm	52.5	17	8	ø16	14430100210
14101001060	ø22		100 bar		1 : 1	6'000 min ⁻¹	60 Nm	52.5	19	10	ø22	14430100130
14101001100	ø22		70 bar		1 : 1	6'000 min ⁻¹	60 Nm	52.5	19	10	ø22	14430100130
14101001080	ø27		100 bar		1 : 1	6'000 min ⁻¹	60 Nm	51.5	21	12	ø27	14430100100
14101001110	ø27		70 bar		1 : 1	6'000 min ⁻¹	60 Nm	51.5	21	12	ø27	14430100100

These units have angular contact ball bearings.
 Diese Einheiten haben Schrägkugellager.
 Questi motorizzati montano cuscinetti a contatto obliquo.
 Ces unités ont des roulements à contact obliques.
 これらのユニットにはアンギュラーコンタクトベアリングを使用

