

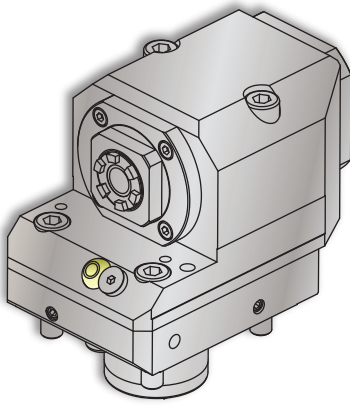

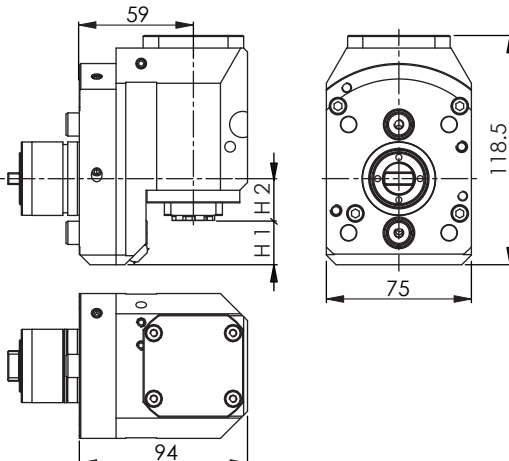





Miyano

Axial Drilling and Milling Unit / Axial-Bohr-Fräseinheit
 Motorizzato Assiale di Foratura e Fresatura / Unité de Perçage et de Fraisage Axiale
 アクシシャルドリルおよびミーリングユニット

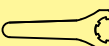
Z-Axis Angular Unit Offset • ZAUO 16-1 A										SU-matic®	
Machine Types	BNA 34 S / C / DHY / MSY / GTY			BNA 42 S / C / DHY / MSY / GTY							
  											
#				$n_1 : n_2$	i $n_1 : n_2$	$n_2 \text{ max}$	$T_2 \text{ max}$	H1	H2	# 	
14800003370	ERAX 16	 100 bar		1:1	6'000 min ⁻¹	16 Nm	22.9	21.6		14430101110	
14800003450	ERAX 20	 100 bar		1:1	6'000 min ⁻¹	16Nm	26.6	17.9		14430101250	

Notes / Notizen / Note / Notes / ㄨ ㄜ

Please check the machine strokes and the neighbor stations on potential overlaps - Bitte die Verfahrswege und die Nachbarstationen auf mögliche Überschneidungen überprüfen
 Si prega di verificare i percorsi e le stazioni adiacenti di potenziali sovrapposizioni - Vérifier les courses et qu'il n'y a pas de collisions possibles avec les stations voisines
 常に機械のストロークと、隣接するステーションにオーバーラップが無いが確認してください。
 Design data and dimensions subject to change - Konstruktions- und Massänderungen vorbehalten
 Cambiamento della costruzione e delle misure riservato - Droit de modification de structure et de cotes réservées
 設計仕様および寸法は通知することなく変更されます

