

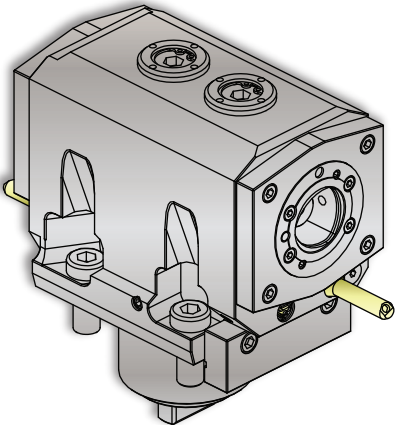

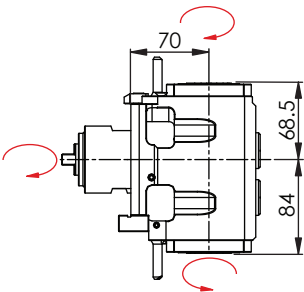
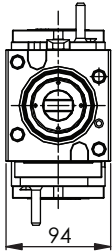
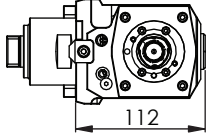

## OKUMA

Axial Drilling and Milling Unit / Axial-Bohr-Fräseinheit  
 Motorizzato Assiale di Foratura e Fresatura / Unité de Perçage et de Fraisage Axiale  
 アキシャルドリルおよびミーリングユニット

Lathe Angular Unit Twin • LAUT 60-1+1 A C4							SU-matic®	
Machine Types	Genos L300 (BMT) MW / MYW	Genos L3000 (BMT) MW	LB2000 EX MW	LB3000 EX MW / MYW	LU3000 EX MW			
    								
#				$i$	$n_2$	$T_2$	#	
14801001070	Capto C4	100 bar	-	1:1	6'000 min <sup>-1</sup>	60 Nm		14430100980

### Notes / Notizen / Note / Notes / ㄨ ㄜ

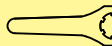
Please check the machine strokes and the neighbor stations on potential overlaps - Bitte die Verfahrswege und die Nachbarstationen auf mögliche Überschneidungen überprüfen  
 Si prega di verificare i percorsi e le stazioni adiacenti di potenziali sovrapposizioni - Vérifier les courses et qu'il n'y a pas de collisions possibles avec les stations voisines  
 常に機械のストロークと、隣接するステーションにオーバーラップが無いが確認してください。  
 Design data and dimensions subject to change - Konstruktions- und Massänderungen vorbehalten  
 Cambiamento della costruzione e delle misure riservato - Droit de modification de structure et de cotes réservées  
 設計仕様および寸法は通知することなく変更されます

