

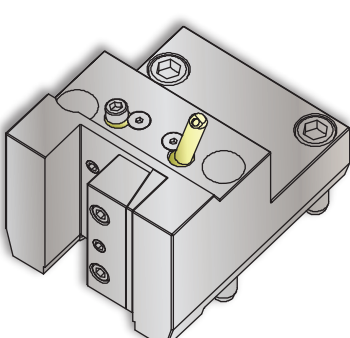

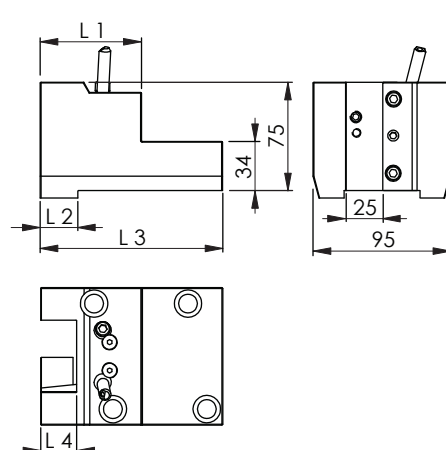

## OKUMA

Length Turning Tool Holder / Überdrehhalter  
 Porta Utensili per Esterni / Porte Outil de Dressage  
 外径ターニングホルダー

Lathe Linear Static • LLS 25-1 R						SU-matic®				
Machine Types	Genos L300 (BMT) M / MW / MY / MYW	Genos L3000 (BMT) M / MW / MY	LB2000 EX M / MW / MY	LB3000 EX M / MW / MY / MYW	LU3000 EX M / MW / MY					
 										
Machine	#			L1	L2	L3	L4	# 		
LB2000	14910000081	□20x25	 100 bar	65	21	121	20	-		
L300 / L3000 LB3000 LU3000	14910000111	□25x25	 100 bar	70	26	126	25	-		

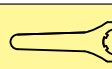
### Notes / Notizen / Note / Notes / ㄨ ㄜ

Please check the machine strokes and the neighbor stations on potential overlaps - Bitte die Verfahrswege und die Nachbarstationen auf mögliche Überschneidungen überprüfen  
 Si prega di verificare i percorsi e le stazioni adiacenti di potenziali sovrapposizioni - Vérifier les courses et qu'il n'y a pas de collisions possibles avec les stations voisines  
 常に機械のストロークと、隣接するステーションにオーバーラップが無いが確認してください。  
 Design data and dimensions subject to change - Konstruktions- und Massänderungen vorbehalten  
 Cambiamento della costruzione e delle misure riservato - Droit de modification de structure et de cotes réservées  
 設計仕様および寸法は通知することなく変更されます

