

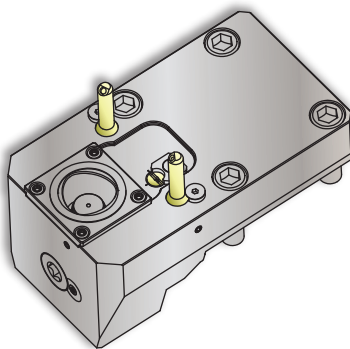

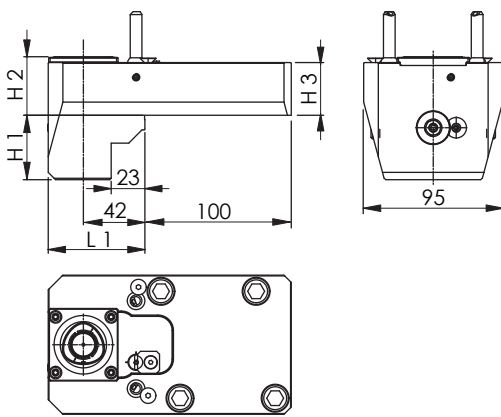



OKUMA

Length Turning Tool Holder / Überdrehhalter
 Porta Utensili per Esterni / Porte Outil de Dressage
 外径ターニングホルダー

Lathe Linear Static Offset • LLSO C4-1 R								SU-matic®	
Machine Types	Genos L300 (BMT) M / MW / MY / MYW	Genos L3000 (BMT) M / MW / MY	LB2000 EX M / MW / MY	LB3000 EX M / MW / MY / MYW	LU3000 EX M / MW / MY				
  									
#			H1	H2	H3	L1			# 
14910002390	Capto C4	 100 bar	44	40	36	66			14430100980
14910004210	Capto C5	 100 bar	35	50	45	74			14430100980

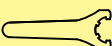
Notes / Notizen / Note / Notes / ㄨ ㄜ

Please check the machine strokes and the neighbor stations on potential overlaps - Bitte die Verfahrswege und die Nachbarstationen auf mögliche Überschneidungen überprüfen
 Si prega di verificare i percorsi e le stazioni adiacenti di potenziali sovrapposizioni - Vérifier les courses et qu'il n'y a pas de collisions possibles avec les stations voisines
 常に機械のストロークと、隣接するステーションにオーバーラップが無いが確認してください。
 Design data and dimensions subject to change - Konstruktions- und Massänderungen vorbehalten
 Cambiamento della costruzione e delle misure riservato - Droit de modification de structure et de cotes réservées
 設計仕様および寸法は通知することなく変更されます

