

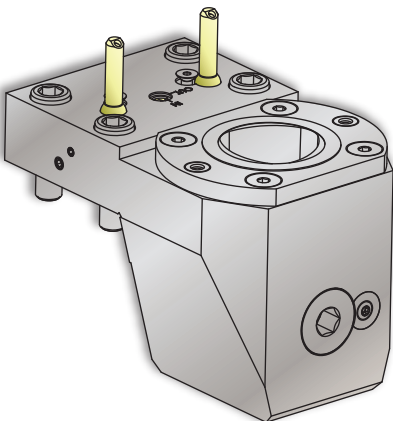

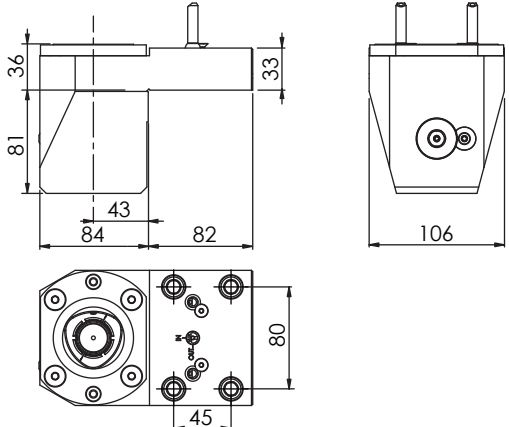



OKUMA

Length Turning Tool Holder / Überdrehhalter
 Porta Utensili per Esterni / Porte Outil de Dressage
 外径ターニングホルダー

Lathe Linear Static Offset • LLSO C6-1 R				SU-matic®
Machine Types	Multus U3000 / U4000 2S-C			
  				
#			# 	
14910004460	Capto C6	 100 bar	14430100980	

Notes / Notizen / Note / Notes / ㄨㄛ

Please check the machine strokes and the neighbor stations on potential overlaps - Bitte die Verfahrswege und die Nachbarstationen auf mögliche Überschneidungen überprüfen
 Si prega di verificare i percorsi e le stazioni adiacenti di potenziali sovrapposizioni - Vérifier les courses et qu'il n'y a pas de collisions possibles avec les stations voisines
 常に機械のストロークと、隣接するステーションにオーバーラップが無いが確認してください。
 Design data and dimensions subject to change - Konstruktions- und Massänderungen vorbehalten
 Cambiamento della costruzione e delle misure riservato - Droit de modification de structure et de cotes réservées
 設計仕様および寸法は通知することなく変更されます

