

Standard Heads for CITIZEN Automatic Lathes

The SU-matic product range has been expanded in the passed years with numerous applications for CITIZEN automatic lathes. In the meantime special heads, like angle heads, with 2 exits up to 12,000 RPM are part of the standard program.







CITIZEN automatic lathe



Standard holder for C16 / K16 resp. MS 32

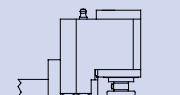
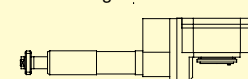
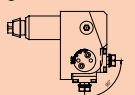
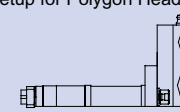
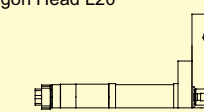
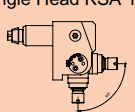
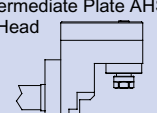
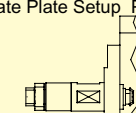
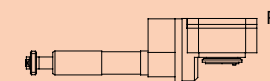
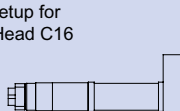
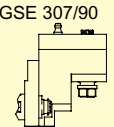

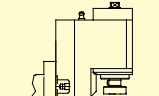
Thread whirling head for L20

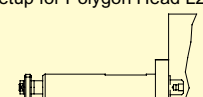
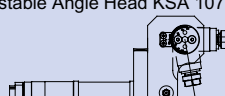
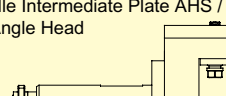
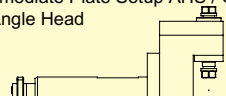
C16-VII	L 20-VII	M32
Polygon Head AHSP 1/1 KSP 405  Page 01	Thread Whirling AHSW 1/1  Page 31	Adjustable Angle Head KSA 107  Page 61
Plate Setup for Polygon Head C16  Page 02	Polygon Head L20  Page 32	Adjustable Angle Head KSA 107 spez.  Page 62
Middle Intermediate Plate AHST 1/2 for Angle Head  Page 03	Intermediate Plate Setup Polygon Head  Page 33	Thread Whirling AHSW 1/1  Page 63
Plate Setup for Angle Head C16  Page 04	AHS I L20 / GSE 307/90  Page 34	
Axial Holder AHS 1 C16 / GSE 807  Page 05	Polygon Head AHSP 1/1 KSP 607  Page 35	
Axial Holder AHS IV C16 / GSE 807  Page 06	Plate Setup for Polygon Head L20  Page 36	
Adjustable Angle Head KSA 107  Page 07	Middle Intermediate Plate AHS / GSE 607 for Angle Head  Page 37	
	Intermediate Plate Setup AHS / GSE 607 for Angle Head  Page 38	

Excerpt of available standard and special heads