

muratec LAU 40-1 A ER25

6'000 min -1 / rpm
i = 1:1

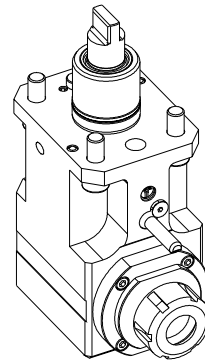
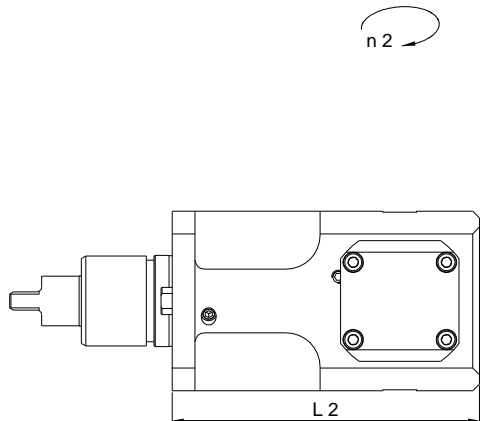
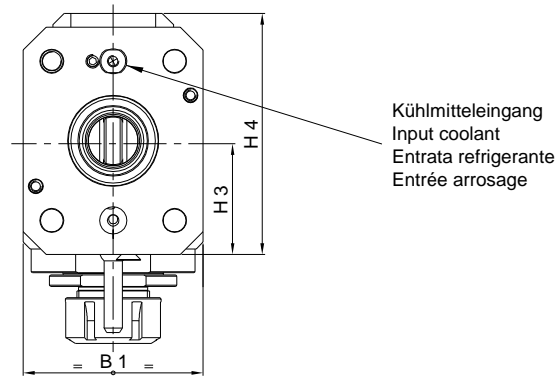
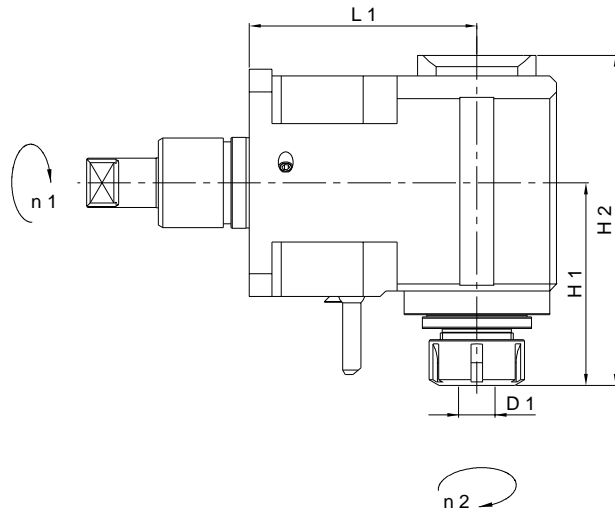
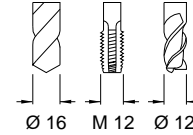

Axial-Bohr-Fräseinrichtung
Drilling and Milling Axial Unit
Testa assiale di foratura e fresatura
Unité de perçage et de fraisage axial

Externe Kühlung EKZ
Interne Kühlmittelzuführung IKZ
P max. = 30 bar
kein Trockenlauf!

External coolant supply ECS
Coolant through the spindle CTS
Coolant pressure max. = 30 bar
Don't run without coolant!

Liquido refrigerante esterno LRE
Liquido refrigerante sul fuso LRF
Pressione max. = 30 bar
Non lavorare a secco!

Arrosage par l'extérieur APE
Arrosage par le centre APC
Pression max. = 30 bars
Ne pas tourner sans arrosage!

	Bestell-Nr. IKZ Ref. No. CTS	Bestell-Nr. EKZ Ref. No. ECS	Axialkopf Axial Head	L 1	L 2	H 1	H 2	H 3	H 4	B 1	D 1 Ø max.	Nm max.	Schmierung Lubrication	rpm max. min -1	i n 1 : n 2	Zubehör Accessory
A	14.800.0.0282.0	-	LAU 40-1 A Hi-Q / ER25	100	135	145	100	50	106	79	16	40	Fettschmierung Lubricant grase	6'000	1:1	Spannzangen / Dichtscheiben / Collets / Sealing Disks Schlüssel / Spanners