

CITIZEN AHS I / GSA 407

5'000 min⁻¹ / rpm
i = 1:1

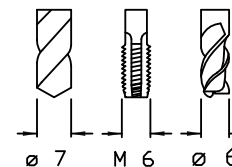

Winkel-Bohr-Fräseinrichtung
Right angle drilling and milling unit
Testa ad angolo di foratura e fresatura
Unité de perçage et de fraisage angulaire

Externe Kühlmittelzuführung
External coolant supply
Liquido refrigerante esterno
Arrosage par l'Exterieur

Version: 03.10.2005 Page 07

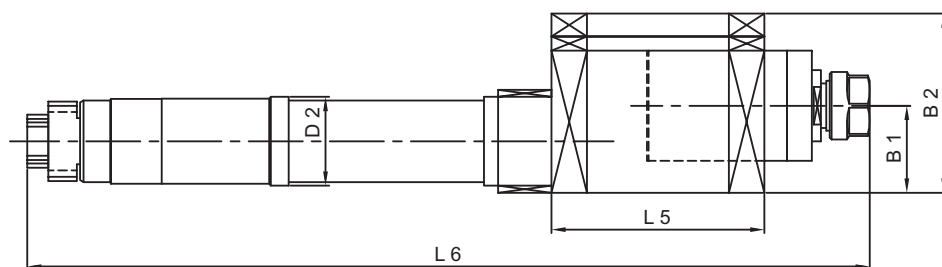
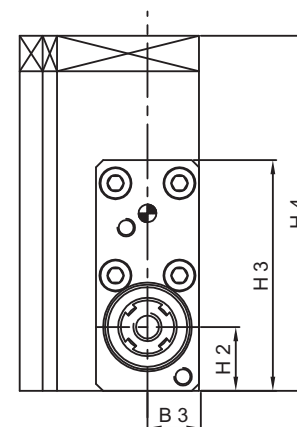
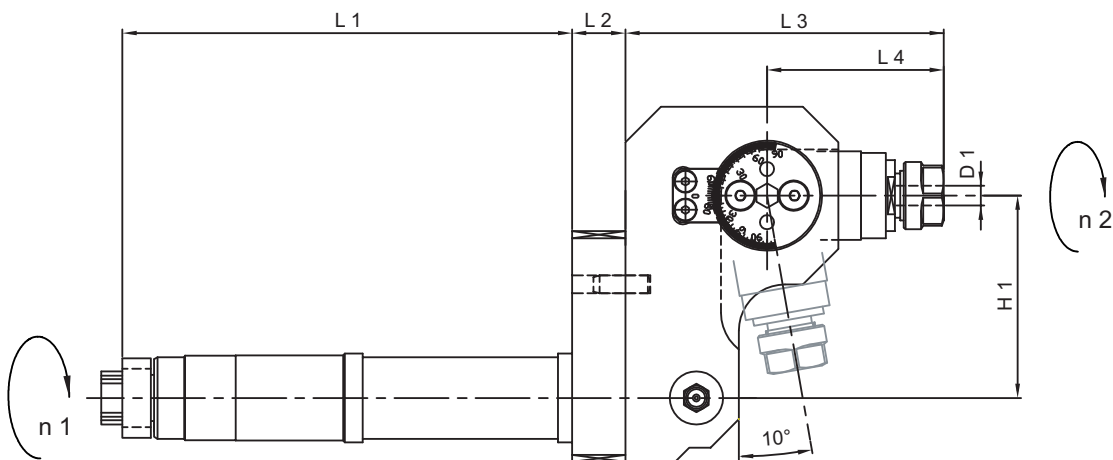

	Bestell-Nr. Ref. No.	Winkelkopf 90° Anglehead	L 1	L 2	L 3	L 4	L 5	L 6	H 1	H 2	H 3	H 4	B 1	B 2	B 3	D 1 Ø max.	D 2 Ø	Nm max.	Schmierung Lubrication	rpm max. min ⁻¹	i n 1 : n 2	Zubehör Accessory
A	14.800.0.0087.0	AHS I /GSA 407 ER 11	126.7	15	104.7	49.8	60	237.4	75	18	65	100	24.5	50.5	14.5	7	25	00	Fettschmierung Lubricant grease	5'000	1:1	-