

CITIZEN Aufbauplatte C16

12'000 min⁻¹ / rpm
i = 1:1

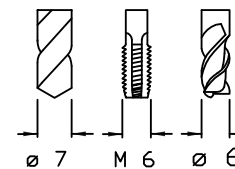

Winkel-Bohr-Fräseinrichtung
Right angle drilling and milling unit
Testa ad angolo di foratura e fresatura
Unité de perçage et de fraisage angulaire

Externe Kühlmittelzuführung

External coolant supply

Liquido refrigerante esterno

Arrosage par l'Exterieur

Version: 03.10.2005 Page 04

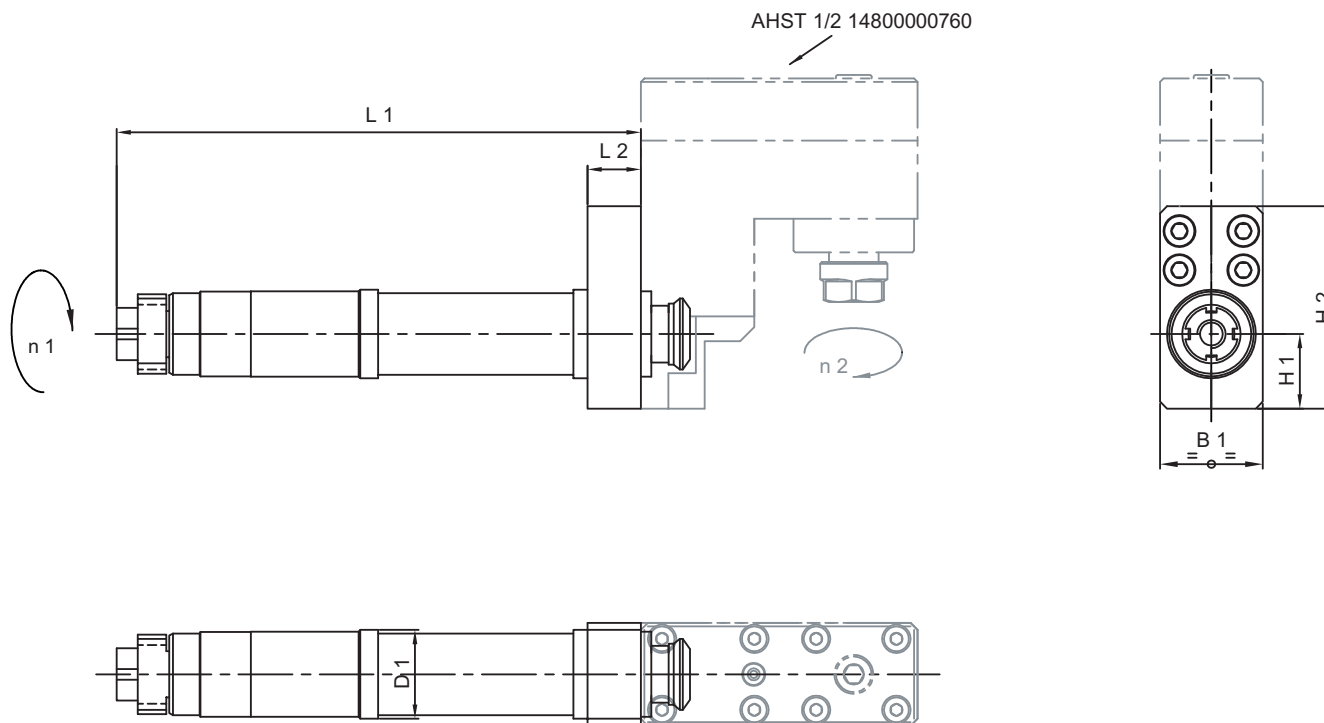

	Bestell-Nr. Ref. No.	Winkelkopf 90° Anglehead	L 1	L 2	H 1	H 2	B 1	D 1 Ø	Nm max.	Schmierung Lubrication	rpm max. min -1	i n 1 : n 2	Zubehör Accessory
A	14.018.7.0025.0	Aufbauplatte Supportplate	147.7	15	21	57	29	25	5.3	Fettschmierung Lubricant grease	12'000	1:1	-

Konstruktions- und Massänderungen vorbehalten - Design data and dimensions subject to change - Cambiamento della costruzione e delle misure riservato - Droit de modification de structure et de cotes réservées