

8'000 min -1 / rpm i = 1:1

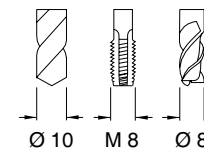

Winkel-Bohr-Fräseinrichtung
Drilling and Milling Angle Unit
Testa ad angolo di foratura e fresatura
Unité de perçage et de fraisage angulaire

Externe Kühlung	EKZ
External coolant supply	ECS
Liquido refrigerante esterno	LRE
Arrosage par l'extérieur	APE

**Einbauposition
T09**

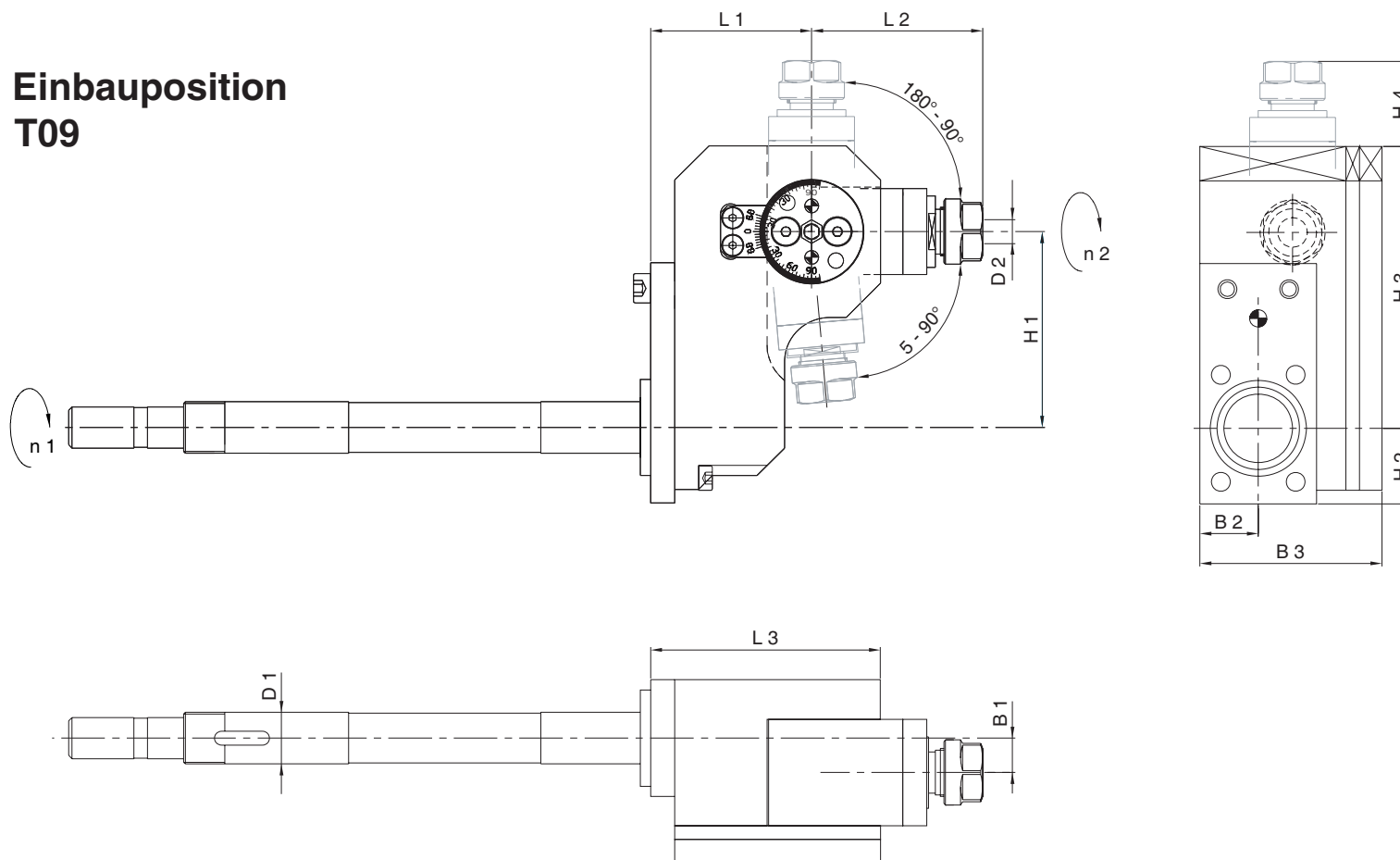

	Bestell-Nr. EKZ Ref. No. ECS	Winkelkopf 5 - 180° Angle Head	L 1	L 2	L 3	H 1	H 2	H 3	H 4	B 1	B 2	B 3	D 1 Ø	D 2 Ø max.	Nm max.	Schmierung Lubrication	rpm max. min -1	i n 1 : n 2	Zubehör Accessory
A	14.825.0.0016.0	LAHS 1 ER 11	46.9	49.8	67	57	22	82	24.8	10	17	53	15	7	2.5	Fettschmierung Lubricant grease	8'000	1 : 1	